



**WAUPACA**  
**ELEVATOR** COMPANY, INC.  
Specify the Specialists®

---

# Planning Guide

---

**Cable-Waiter™**  
**Paca-Waiter®**  
**Dumbwaiters**





We are a proud member of the Accessibility Equipment Manufacturers Association. This symbol assures you of our commitment to high quality and accessibility to everyone.

## Waupaca Elevator Mission Statement

Our company's mission is to supply and service products that meet or exceed our customers' expectations of high quality, value, delivery and longevity. Our success is a direct reflection of our employees' involvement and commitment to excellence. We strive to continuously improve our products to ensure meeting the future requirements of our customers and facilitate competitive growth.

## Table of Contents

Introduction .....	4
Quick Guide to Dumbwaiters & Features .....	5
Dumbwaiter Hoistway Illustration .....	6
Dumbwaiter Series Information .....	7
Hoistway Layout .....	8-12
Electrical Room .....	13
Dumbwaiter Equipment .....	14
Dumbwaiter Series Examples .....	15
Elevation Layout for Bi-Part Doors .....	16



---

# Introduction

This Planning Reference Guide is to be used as a guide in deciding the type of dumbwaiter to be installed, parameters of installation and steps taken to achieve a proper dumbwaiter installation. This guide may be used by the architect, contractor, dealer or home owner. The information in this guide is intended as an overview, each installation will have job specific specifications that must be followed. Do not attempt to construct a hoistway on this information alone.

Dumbwaiter installation is to be done by an authorized elevator contractor, and in accordance with installation instructions provided by the manufacturer. Installation must also be in compliance with requirements of the National Electric Code, American Society of Mechanical Engineers safety code, and state and local building codes. Waupaca Elevator's products are designed to meet the requirements of ASME - 17.1 National Elevator Codes for dumbwaiters and are fully certified by a registered professional engineer. Waupaca Elevator Company, Inc. dumbwaiters manufactured and installed under the proper parameters are warranted for 2 years. Manufacturer assumes no liability for equipment not installed in compliance with these codes.

---

# Planning Steps

1. - Locate local dealer and together determine the following:
  - A - Select drive system, car type and design specifications
  - B - Address national, state and local code requirements
  - C - Hoistway size
  - D - Car size, layout and options
  - E - Machine room location and layout
  - F - Electrical requirements
2. - Obtain and follow site specific field drawings while building hoistway, doorways and any other construction related to the dumbwaiter.
3. - Coordinate with dealer to install dumbwaiter.



## Dumbwaiter Quick Reference Guide

Mechanical Features	Cable-Waiter		Paca-Waiter		
	50 lbs.	100 lbs.	200 lbs.	300 lbs.	500 lbs.
Weight Capacity	50 lbs.	100 lbs.	200 lbs.	300 lbs.	500 lbs.
Standard Car Size	16"x16"x24"	20"x20"x30"	26"x26"x36"	30"x30"x40"	36"x36"x48"
Motor	3/4 HP	3/4 HP	1 HP	2 HP	2 HP
Phase	Single	Single	Single/Three	Single/Three	Single/Three
Volts	110	110	208, 230	208, 230	208, 230
Amps	20	20	20/30	20/30	20/30
Controller Size	18"x18"x6"	18"x18"x6"	18"x18"x6"	18"x18"x6"	18"x18"x6"
Sheave Diameter	4"	4"	6-3/8"	6-3/8"	7-1/2"
Drum Diameter	5-1/4"	5-1/4"	5-3/4"	5-3/4"	6-3/4"
Rails	1-1/2 x 1-1/2 x 1/8 Angle Steel		2 x 1 x 3/16 C-Channel Steel		
Cables	1/8 x 7 x 19		3/16 x 7 x 19		7/32 x 7 x 19

Optional Features	Description
Machine Placement	Rail Mounted: Above Car, Below Car
Car	Primed Steel, Stainless Steel, Wood
Car Opening	Single, Opposite, Adjacent
Access Door	Stainless Steel, Primed Steel
Gates	Bi-Part - Slide Up (primed steel or stainless), Roll Top (wood on roll top only)
Hall Station Options	Door Open Buzzer, Car Here, Call & Send, In Use Light, Lantern & Gong
Safety Locks	Single Contact Interlock: GAL, EMI, HGI (provided with hoistway door)

# Hoistway Illustrations - Dumbwaiters

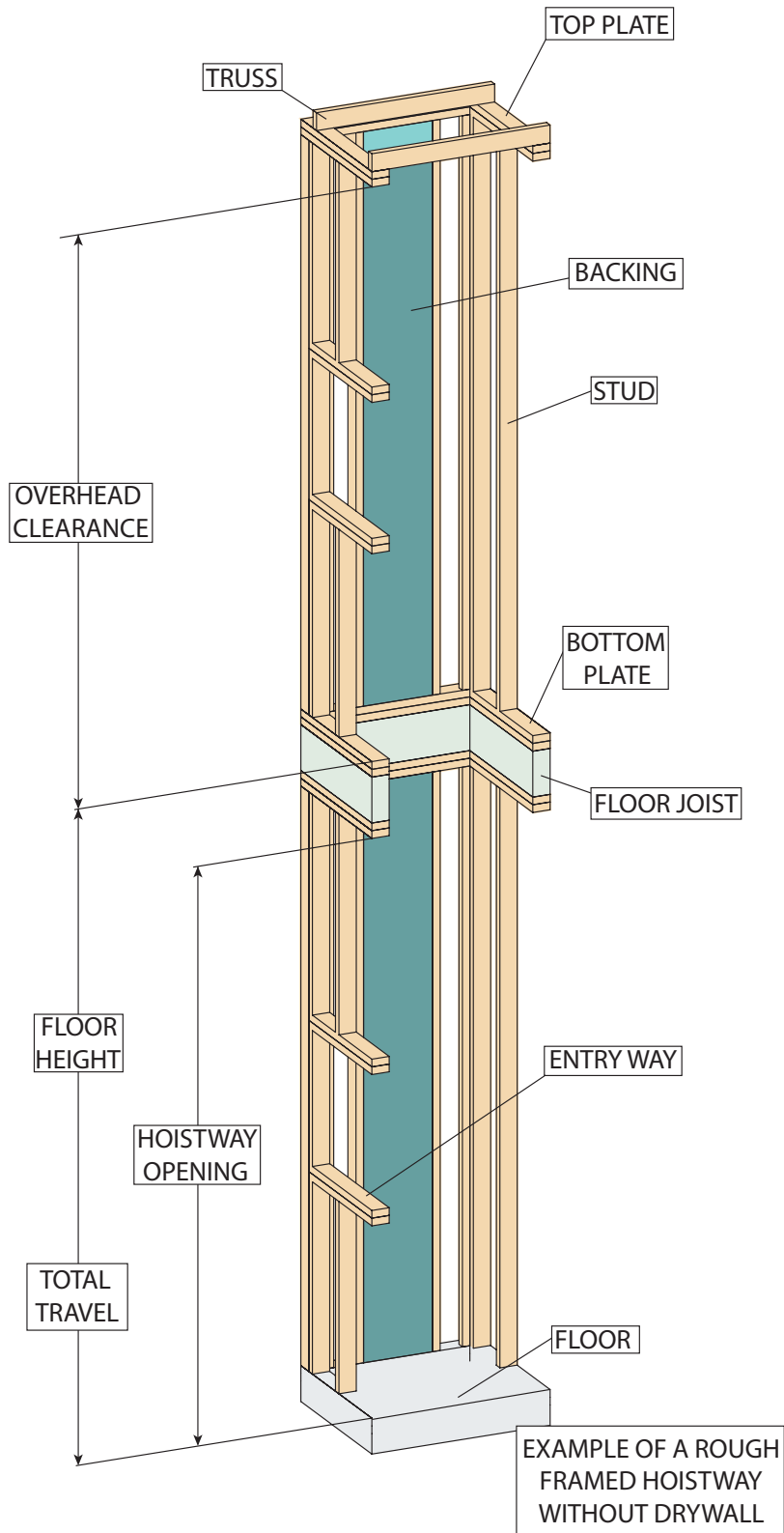

# Paca-Waiter<sup>®</sup> Cable Waiter<sup>™</sup> Dumbwaiters

Series	<b>007</b>	50 lbs.	<b>011</b>	200 lbs.
		100 lbs.		300 lbs.
				500 lbs.

## Construction Notes:

- Use specified backing from architect to frame into wall.
- The following hoistways are showing finished dimensions. Finished hoistway dimensions include drywall installation, plaster and paint.
- Rough frame door in place with an extra inch of space on all sides of the door to later install the door and door trim.
- Do not complete door and associated framing to one door (preferably at grade level), until dumbwaiter installation is complete.

The dumbwaiters listed in the following section are based upon our standard car. Cars can be customized to meet your unique needs.



# Hoistway Layout - Dumbwaiters

## Steel Car with Gates

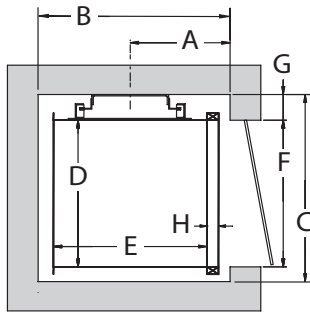

### RIGHT OPENING (AB)

Dumbwaiter Type	Car Size	GATED DUMBWAITER							
		Finished Hoistway Dimensions							
RIGHT OPENING		A	B	C	D	E	F	G	H
Cable-Waiter 50 lbs.	16"x16"x24"	11"	22"	21.5"	16"	16"	16"	3.5"	1.5"
Cable-Waiter 100 lbs.	20"x20"x30"	13"	25"	25.5"	20"	20"	20"	3.5"	1.5"
Paca-Waiter 200 lbs.	26"x26"x36"	16"	31"	33.25"	26"	26"	26"	4.25"	1.5"
Paca-Waiter 300 lbs.	30"x30"x40"	18"	35"	37.25"	30"	30"	30"	4.25"	1.5"
Paca-Waiter 500 lbs.	36"x36"x48"	21"	41"	43.25"	36"	36"	36"	4.25"	1.5"

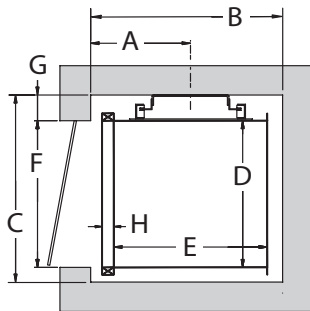

### LEFT OPENING (DC)

Dumbwaiter Type	Car Size	GATED DUMBWAITER							
		Finished Hoistway Dimensions							
LEFT OPENING		A	B	C	D	E	F	G	H
Cable-Waiter 50 lbs.	16"x16"x24"	11"	21"	21.5"	16"	16"	16"	3.5"	1.5"
Cable-Waiter 100 lbs.	20"x20"x30"	13"	25"	25.5"	20"	20"	20"	3.5"	1.5"
Paca-Waiter 200 lbs.	26"x26"x36"	16"	31"	33.25"	26"	26"	26"	4.25"	1.5"
Paca-Waiter 300 lbs.	30"x30"x40"	18"	35"	37.25"	30"	30"	30"	4.25"	1.5"
Paca-Waiter 500 lbs.	36"x36"x48"	21"	41"	43.25"	36"	36"	36"	4.25"	1.5"

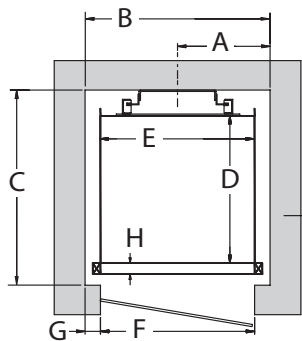

### FRONT OPENING (CB)

Dumbwaiter Type	Car Size	GATED DUMBWAITER							
		Finished Hoistway Dimensions							
FRONT OPENING		A	B	C	D	E	F	G	H
Cable-Waiter 50 lbs.	16"x16"x24"	10"	21"	22.5"	16"	16"	16"	3"	1.5"
Cable-Waiter 100 lbs.	20"x20"x30"	12"	24"	26.5"	20"	20"	20"	2"	1.5"
Paca-Waiter 200 lbs.	26"x26"x36"	16"	32"	33.25"	26"	26"	26"	3"	1.5"
Paca-Waiter 300 lbs.	30"x30"x40"	18"	36"	37.25"	30"	30"	30"	3"	1.5"
Paca-Waiter 500 lbs.	36"x36"x48"	21"	42"	43.25"	36"	36"	36"	3"	1.5"





# Hoistway Layout - Dumbwaiters

## Steel Car with Gates

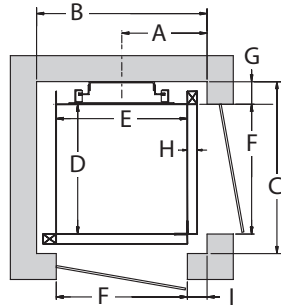

### RIGHT ADJACENT OPENINGS (AB CB)

Dumbwaiter Type	GATED DUMBWAITER									
	Car Size	Finished Hoistway Dimensions								
A		B	C	D	E	F	G	H	I	
<b>Right Adjacent Open</b>										
Cable-Waiter 50 lbs.	16"x16"x24"	11"	22"	22.5"	16"	16"	16"	3.5"	1.5"	3"
Cable-Waiter 100 lbs.	20"x20"x30"	13"	26"	26.5"	20"	20"	20"	3.5"	1.5"	3"
Paca-Waiter 200 lbs.	26"x26"x36"	16"	32"	33.25"	26"	26"	26"	4.25"	1.5"	3"
Paca-Waiter 300 lbs.	30"x30"x40"	18"	36"	37.25"	30"	30"	30"	4.25"	1.5"	3"
Paca-Waiter 500 lbs.	36"x36"x48"	21"	42"	43.25"	36"	36"	36"	4.25"	1.5"	3"

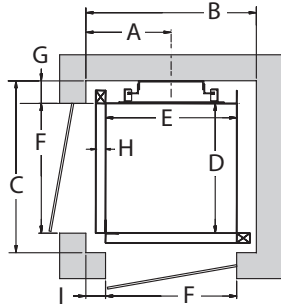

### LEFT ADJACENT OPENINGS (DC BC)

Dumbwaiter Type	GATED DUMBWAITER									
	Car Size	Finished Hoistway Dimensions								
A		B	C	D	E	F	G	H	I	
<b>Left Adjacent Open</b>										
Cable-Waiter 50 lbs.	16"x16"x24"	11"	22"	22.5"	16"	16"	16"	3.5"	1.5"	3"
Cable-Waiter 100 lbs.	20"x20"x30"	13"	26"	26.5"	20"	20"	20"	3.5"	1.5"	3"
Paca-Waiter 200 lbs.	26"x26"x36"	16"	32"	33.25"	26"	26"	26"	4.25"	1.5"	3"
Paca-Waiter 300 lbs.	30"x30"x40"	18"	36"	37.25"	30"	30"	30"	4.25"	1.5"	3"
Paca-Waiter 500 lbs.	36"x36"x48"	21"	42"	43.25"	36"	36"	36"	4.25"	1.5"	3"

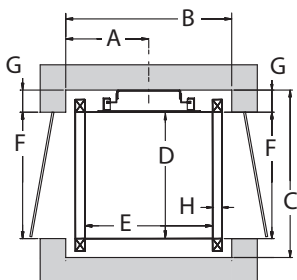

### OPPOSITE OPENINGS (AB DC)

Dumbwaiter Type	GATED DUMBWAITER								
	Car Size	Finished Hoistway Dimensions							
A		B	C	D	E	F	G	H	
<b>Opposite Openings</b>									
Cable-Waiter 50 lbs.	16"x16"x24"	11"	22"	22.5"	16"	16"	16"	3.5"	1.5"
Cable-Waiter 100 lbs.	20"x20"x30"	13"	26"	26.5"	20"	20"	20"	3.5"	1.5"
Paca-Waiter 200 lbs.	26"x26"x36"	16"	32"	33.25"	26"	26"	26"	4.25"	1.5"
Paca-Waiter 300 lbs.	30"x30"x40"	18"	36"	37.25"	30"	30"	30"	4.25"	1.5"
Paca-Waiter 500 lbs.	36"x36"x48"	21"	42"	43.25"	36"	36"	36"	4.25"	1.5"



# Hoistway Layout - Dumbwaiter

## Steel Car with Gates and Commercial Doors

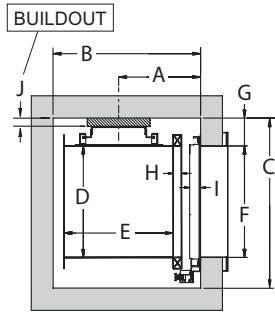

### RIGHT OPENING (AB)

Dumbwaiter Type	GATED DUMBWAITER WITH COMMERCIAL DOOR										
	Car Size	Finished Hoistway Dimensions									
Right Opening		A	B	C	D	E	F	G	H	I	J
Cable-Waiter 50 lbs.	16"x16"x24"	13"	24"	26.5"	16"	16"	16"	5"	1.5"	2"	1.5"
Cable-Waiter 100 lbs.	20"x20"x30"	15"	27"	30.5"	20"	20"	20"	5"	1.5"	2"	1.5"
Paca-Waiter 200 lbs.	26"x26"x36"	18"	33"	36.5"	26"	26"	26"	5"	1.5"	2"	.75"
Paca-Waiter 300 lbs.	30"x30"x40"	20"	37"	40.5"	30"	30"	30"	5"	1.5"	2"	.75"
Paca-Waiter 500 lbs.	36"x36"x48"	23"	43"	46.5"	36"	36"	36"	5"	1.5"	2"	.75"

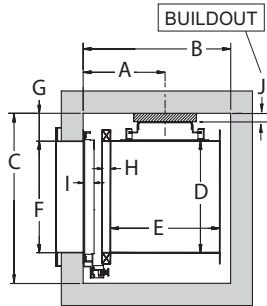

### LEFT OPENING (DC)

Dumbwaiter Type	GATED DUMBWAITER WITH COMMERCIAL DOOR										
	Car Size	Finished Hoistway Dimensions									
Left Opening		A	B	C	D	E	F	G	H	I	J
Cable-Waiter 50 lbs.	16"x16"x24"	13"	23"	26.5"	16"	16"	16"	5"	1.5"	2"	1.5"
Cable-Waiter 100 lbs.	20"x20"x30"	15"	27"	30.5"	20"	20"	20"	5"	1.5"	2"	1.5"
Paca-Waiter 200 lbs.	26"x26"x36"	18"	33"	36.5"	26"	26"	26"	5"	1.5"	2"	.75"
Paca-Waiter 300 lbs.	30"x30"x40"	20"	37"	40.5"	30"	30"	30"	5"	1.5"	2"	.75"
Paca-Waiter 500 lbs.	36"x36"x48"	23"	43"	46.5"	36"	36"	36"	5"	1.5"	2"	.75"

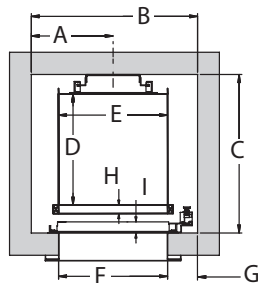

### FRONT OPENING (CB)

Dumbwaiter Type	GATED DUMBWAITER WITH COMMERCIAL DOOR									
	Car Size	Finished Hoistway Dimensions								
Front Opening		A	B	C	D	E	F	G	H	I
Cable-Waiter 50 lbs.	16"x16"x24"	13"	26.5"	24.5"	16"	16"	16"	5.5"	1.5"	2"
Cable-Waiter 100 lbs.	20"x20"x30"	15"	30.5"	28.5"	20"	20"	20"	5.5"	1.5"	2"
Paca-Waiter 200 lbs.	26"x26"x36"	18"	36.5"	35.25"	26"	26"	26"	5.5"	1.5"	2"
Paca-Waiter 300 lbs.	30"x30"x40"	20"	40.5"	39.25"	30"	30"	30"	5.5"	1.5"	2"
Paca-Waiter 500 lbs.	36"x36"x48"	23"	46.5"	45.25"	36"	36"	36"	5.5"	1.5"	2"



# Hoistway Layout - Dumbwaiter

## Steel Car with Gates and Commercial Doors

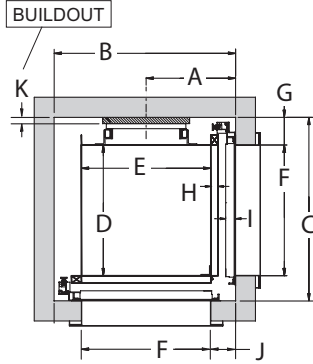

### RIGHT ADJACENT OPENINGS (AB CB)

Dumbwaiter Type	GATED DUMBWAITER WITH COMMERCIAL DOOR											
	Car Size	Finished Hoistway Dimensions										
Right Adjacent Open		A	B	C	D	E	F	G	H	I	J	K
Paca-Waiter 200 lbs.	26"x26"x36"	18"	36.5"	36.5"	26"	26"	26"	5.5"	1.5"	2"	5"	1.25"
Paca-Waiter 300 lbs.	30"x30"x40"	20"	40.5"	40.5"	30"	30"	30"	5.5"	1.5"	2"	5"	1.25"
Paca-Waiter 500 lbs.	36"x36"x48"	23"	46.5"	46.5"	36"	36"	36"	5.5"	1.5"	2"	5"	1.25"

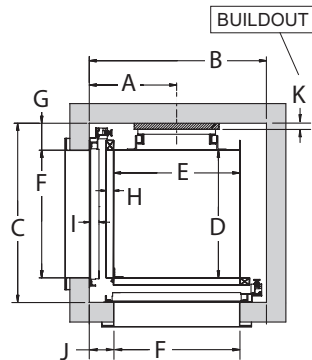

### LEFT ADJACENT OPENINGS (DC BC)

Dumbwaiter Type	GATED DUMBWAITER WITH COMMERCIAL DOOR											
	Car Size	Finished Hoistway Dimensions										
Left Adjacent Open		A	B	C	D	E	F	G	H	I	J	K
Paca-Waiter 200 lbs.	26"x26"x36"	18"	36.5"	36.5"	26"	26"	26"	5.5"	1.5"	2"	5"	1.25"
Paca-Waiter 300 lbs.	30"x30"x40"	20"	40.5"	40.5"	30"	30"	30"	5.5"	1.5"	2"	5"	1.25"
Paca-Waiter 500 lbs.	36"x36"x48"	23"	46.5"	46.5"	36"	36"	36"	5.5"	1.5"	2"	5"	1.25"

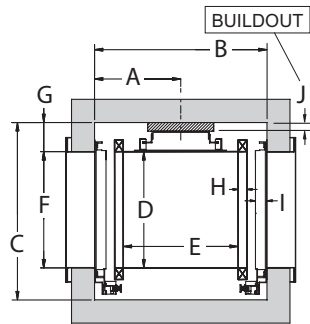

### OPPOSITE OPENINGS (AB DC)

Dumbwaiter Type	GATED DUMBWAITER WITH COMMERCIAL DOOR										
	Car Size	Finished Hoistway Dimensions									
Opposite Opening		A	B	C	D	E	F	G	H	I	J
Cable-Waiter 50 lbs.	16"x16"x24"	13"	26"	26.5"	16"	16"	16"	5"	1.5"	2"	1.5"
Cable-Waiter 100 lbs.	20"x20"x30"	15"	30"	30.5"	20"	20"	20"	5"	1.5"	2"	1.5"
Paca-Waiter 200 lbs.	26"x26"x36"	18"	36"	36.5"	26"	26"	26"	5"	1.5"	2"	.75"
Paca-Waiter 300 lbs.	30"x30"x40"	20"	40"	40.5"	30"	30"	30"	5"	1.5"	2"	.75"
Paca-Waiter 500 lbs.	36"x36"x48"	23"	46"	46.5"	36"	36"	36"	5"	1.5"	2"	.75"



# Hoistway Layout - Dumbwaiter

## Wood Car with Classic Roll Top Gates

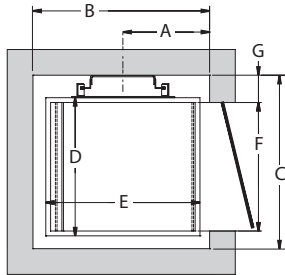

### RIGHT OPENINGS (AB)

Dumbwaiter Type	GATED WOOD DUMBAWAITER							
	Car Size	Finished Hoistway Dimensions						
Right Opening		A	B	C	D	E	F	G
Cable-Waiter 50 lbs.	16"x16"x24"	11.5"	23.5"	23"	17.5"	20"	16"	4.25"
Cable-Waiter 100 lbs.	20"x20"x30"	13.5"	27.5"	27"	21.5"	24"	20"	4.25"
Paca-Waiter 200 lbs.	26"x26"x36"	16.5"	33.5"	33.75"	27.5"	30"	26"	5"

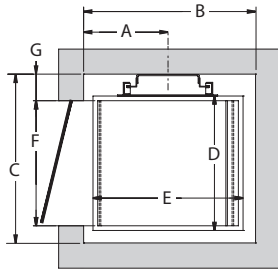

### LEFT OPENINGS (DC)

Dumbwaiter Type	GATED WOOD DUMBAWAITER							
	Car Size	Finished Hoistway Dimensions						
Left Opening		A	B	C	D	E	F	G
Cable-Waiter 50 lbs.	16"x16"x24"	11.5"	23.5"	23"	17.5"	20"	16"	4.25"
Cable-Waiter 100 lbs.	20"x20"x30"	13.5"	27.5"	27"	21.5"	24"	20"	4.25"
Paca-Waiter 200 lbs.	26"x26"x36"	16.5"	33.5"	33.75"	27.5"	30"	26"	5"

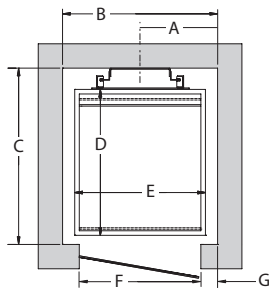

### FRONT OPENINGS (CB)

Dumbwaiter Type	GATED WOOD DUMBAWAITER							
	Car Size	Finished Hoistway Dimensions						
Front Opening		A	B	C	D	E	F	G
Cable-Waiter 50 lbs.	16"x16"x24"	10.75"	21.75"	25"	20"	17.5"	16"	2.75"
Cable-Waiter 100 lbs.	20"x20"x30"	12.75"	25.5"	29"	24"	21.5"	20"	2.75"
Paca-Waiter 200 lbs.	26"x26"x36"	15.75"	31.5"	35.75"	30"	27.5"	26"	2"



# Electrical Room - Dumbwaiters

## Typical Electrical Layout

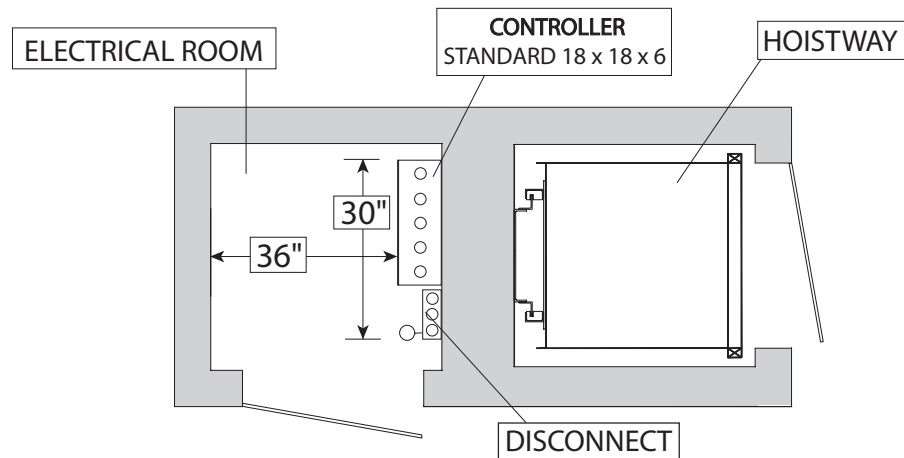

1. The controller requires a clear space of 36" X 30" directly in front of it (refer to example above).
2. A lockable service disconnect must be placed within sight of the controller and easily accessible from the latch side of the doorway.
3. The temperature should be maintainable between 50° F - 100° F and should not be exposed to the elements.

# Dumbwaiter Equipment

## Typical

- Powerhead
- Main Rail
- Gear Box
- Sheaves
- Interlocks
- Motor
- Drum

### PACA-WAITER

#### POWERHEAD

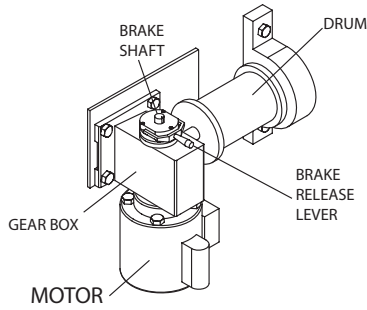

### CABLE-WAITER

#### POWERHEAD

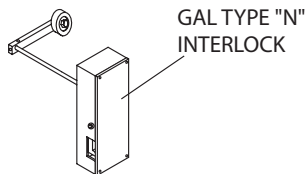
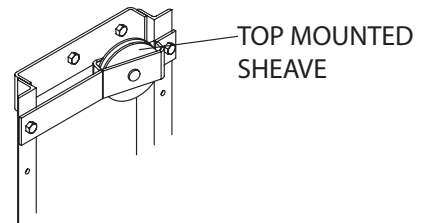
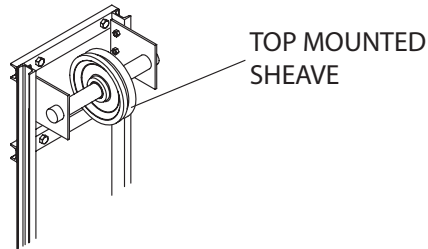
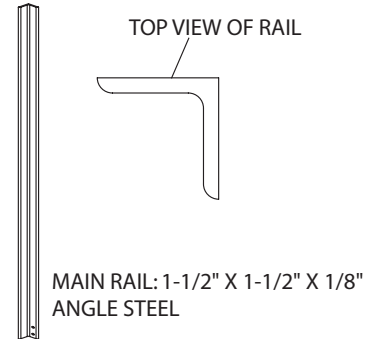
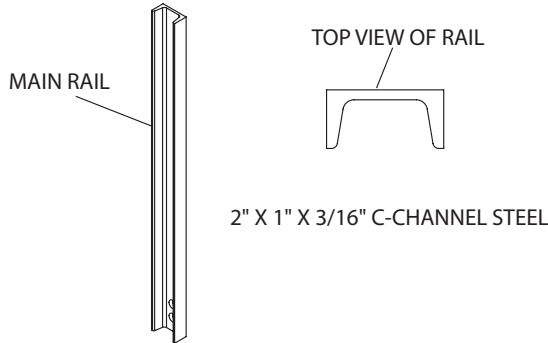
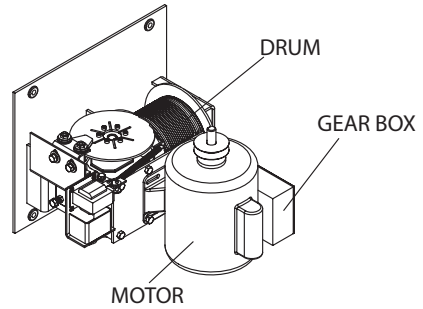

HOISTWAY DOOR INTERLOCKS  
EMI OR GAL TYPE "N" REQUIRED  
AT EACH OPENING TO PREVENT  
HOISTWAY OR DUMBWAITER  
ACCESS WHILE DUMBWAITER  
IS OPERATING OR AT ANOTHER  
LANDING.

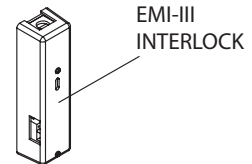

# Cable-Waiter Series 007

## Paca-Waiter Series 011

CABLE-WAITER

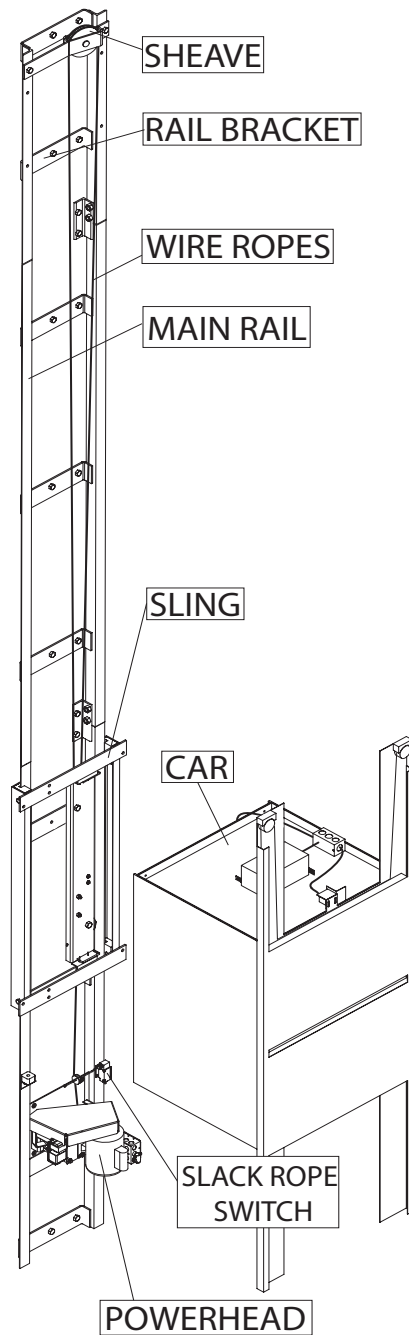

PACA-WAITER

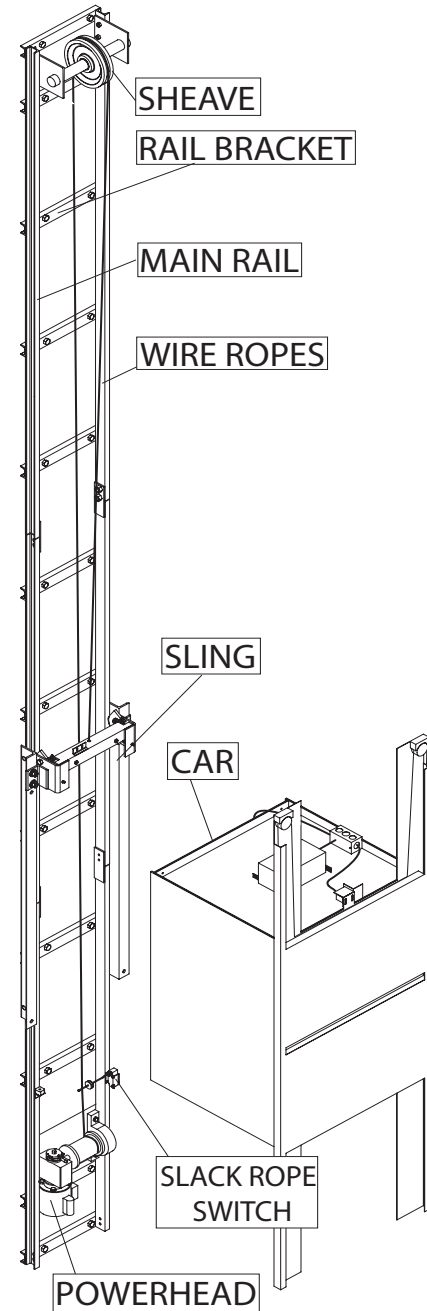

# Elevation Layout for Bi-Parting Doors

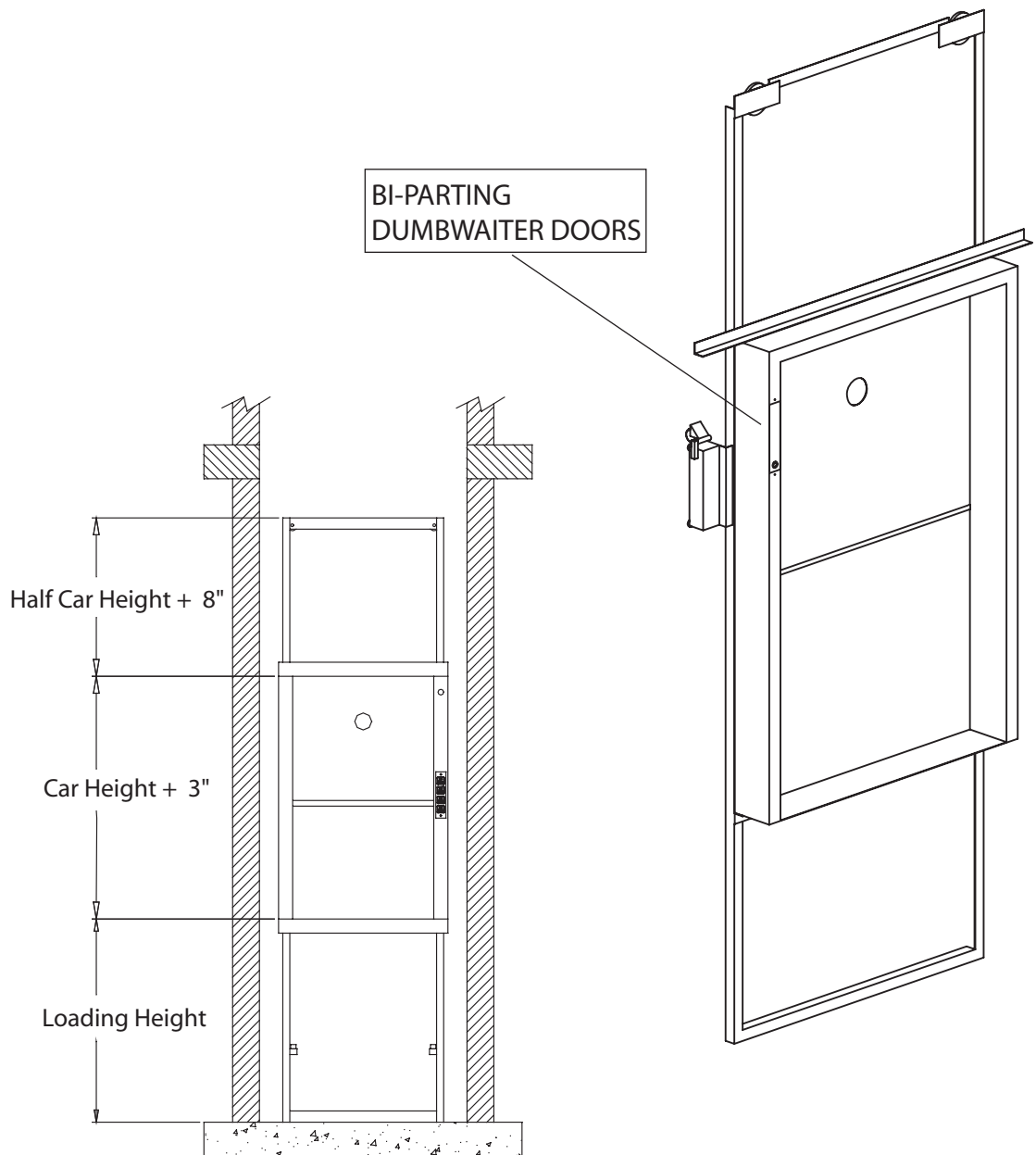

**Note:**  
Recommended to leave entire hoistway wall open for door installation









PMQ0400  
APRIL 2006

1726 North Ballard Road • Appleton, WI 54911  
Phone 920-991-9082 • [www.waupacaelevator.com](http://www.waupacaelevator.com)

